

Pin Location	Description	Color
A	Power Input, Vcc	Red
B	Pedal Signal Output, Vs	Green
C	Ground	Black
D	Return (Switch)	Yellow
E	FS1 (Switch) : NO	Blue
-	-	-

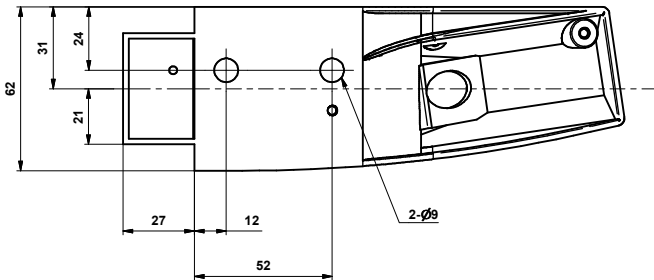

Fig. 1 Circuit Diagram

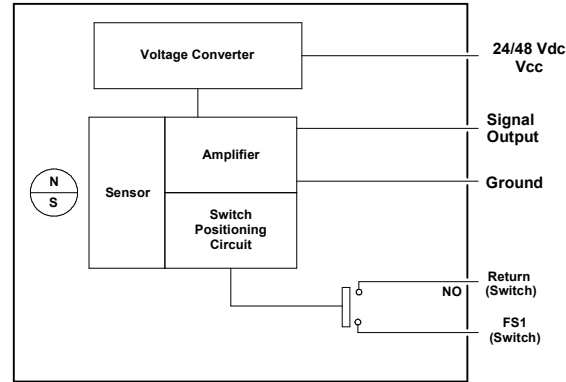

Fig. 2 Signal Output

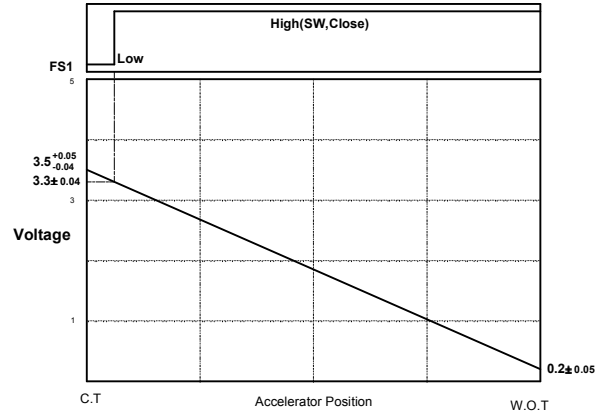
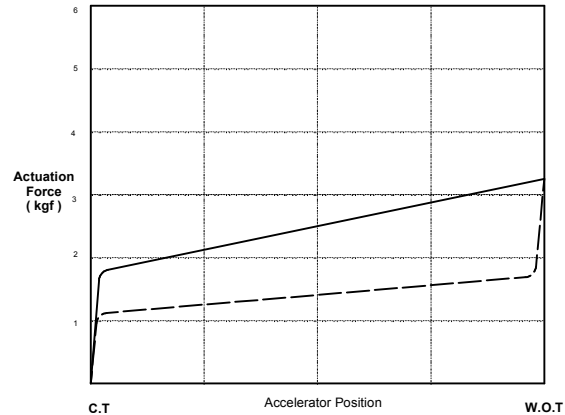

Fig. 3 Spring Force



- General Layout
 - Non - Contact Sensing Technology.
 - This drawing is satisfied with SAE J1843.
 - International Patent Pending.
 - Mechanical Conditions
 - A static pedal force is applied at a point of 150mm from the pedal pivot axis and perpendicular to the pedal surface.
 - (Initial Load : 0.9kgf(MIN), Full Throttle : 3.3kgf(MAX))
 - End-Break force : 160kgf± 5kgf will not damage any pedal parts.
 - Two return spring, inner and outer spring, incorporated to return pedal to idle on release of actuation force.
 - Electrical Conditions
 - Environmental Conditions:
 - Operating Temperature : -40°C ~ +85°C
 - Storage Temperature : -50°C ~ +120°C
 - Electrical Characteristics
 - Type of sensing element
 - Input Voltage(Vcc)
 - Allowable 24/48 Vdc (Rated Battery source)
 - Operative 15 ~ 65 Vdc (Variable Battery source)
 - Operation Current(Iop)
 - 24V : 25mA(Normal), 30mA(Max)
 - 48V : 10mA(Normal), 15mA(Max)
 - Reverse Pararity : Withstand 10min
 - Electrical Travel : See Fig 2.
 - Independent Linearity : ±2%
 - Signal Load : 10kohms, C=4.7nF Tested.
 - Type of switch(SW) : Semiconductor Relay Switch
 - Switch Working Current Range : 0.05mA - 12mA
 - Max Current 20mA
 - Switch Operation Current (Isw) : 10mA
 - Switch Resistance : 1KΩ ± 10% at switch closed, ≥ 100MΩ at switch open
 - Switch Pararity : No parity
 - Switch Voltage : 5V, 12V, 24V
 - Switch Position
 - Switch Position shall be discussed at PO and fixed at factory before delivery. See Fig.2
- Mechanical Specifications
 - 3-1 Mechanical Travel : 17.5 ± 2
- Electrical Connection
 - AMP J - Series Connector : for 6 wire 174264 - 2 (CAP)
- Material
 - Pedal Foot Plate : PA66+GF33%+Anti Static
 - Pedal Bottom Plate : Aluminum (ADC12)
 - Cable : AEXf or AVXf (0.50mm²)
- Marking
 - Sensor serial number and pedal production number shall be indicated and recorded before despatch at factory.
- Durability
 - Subject to over 10million cycles between idle and full throttle position at a rate of approx. 100 cycles per minute.
 - Any wear observed, e.g., on the mechanical stops checked to be in compliance with the initial condition values.
- Environment Test

Item	Test Method	Decision Standard
Vibration Test	Subject to broadband random vibration between 20 and 2000Hz for 20hours in all 3 axis.	Normal Operation
Shock Test	After Exposed to Acceleration 20g (ZERO to PEAK) for 1ms	Normal Operation
Impact Test	Subject to a drop test onto a smooth concrete floor from a height of one meter a total of 6 times	Normal Operation
Temp. Test	After Exposed to -40°C ~ 85°C (100 cycles)	Normal Operation
Humidity Test	After Exposed to -32°C ~ 70°C (98%)	Normal Operation
Salt Fog Test	After Exposed to Salt Fog for 96 Hours (JIS Z2371)	Normal Operation
Chemical Test	Exposed to 3 second dipping in each of the test fluids, followed by a 3 minutes air dry	Normal Operation
ESD Test	Tested in accordance with IEC 61000-4-2 Spec	25KV(Air Discharge)
EMS Test	As per ISO 11452-2 (2004E)	100V/m

ComeSys Control & Measurement Systems Limited		Name	
General Tolerance For Machining: ISO H7/D9		Electronic Accelerator Pedal Assy	
The intellectual property of ComeSys Ltd. Any reproduction in part or in whole without the written permission of ComeSys Ltd. is prohibited.		Application Model	
http://www.come-sys.com		SEVCON Asia	
Rev	Date	Weight	Heat Treatment
D.H.Shin	03.Jan.11	-	-
J.I.Kim	03.Jan.11	-	-
H.M.Lee	03.Jan.11	-	-
Sheet 1 of 1		Customer Part No.	
		FZ3-123-32	